

■ INGENUITY
■ FOR
■ HEALTH

CAMERAS

INGENIOUS
—————
m e d i c a l

1. CAMERA SYSTEM DEFINITION
2. IMAGE FORMATION WORKFLOW
3. CHU CHIP TECHNOLOGY
4. RESOLUTION
5. 4K VS FHD
6. TERMINOLOGIES & SETTINGS
7. CONNECTIONS
8. CAMERA CONTROL UNIT MODELS
9. COMPARAISON
10. TAKE HOME MESSAGE

- The camera system is used to visualize anatomical structures of the human body.
- The camera system is composed of **CAMERA HEAD UNIT(CHU)** and **CAMERA CONTROL UNIT (CCU)**.
- The camera system is the doctor's eye in the patient.



- Delivering a high quality clear **image** for the user this is the doctor's eye in the patient
- Safe
- Accurate
- Intuitive and easy

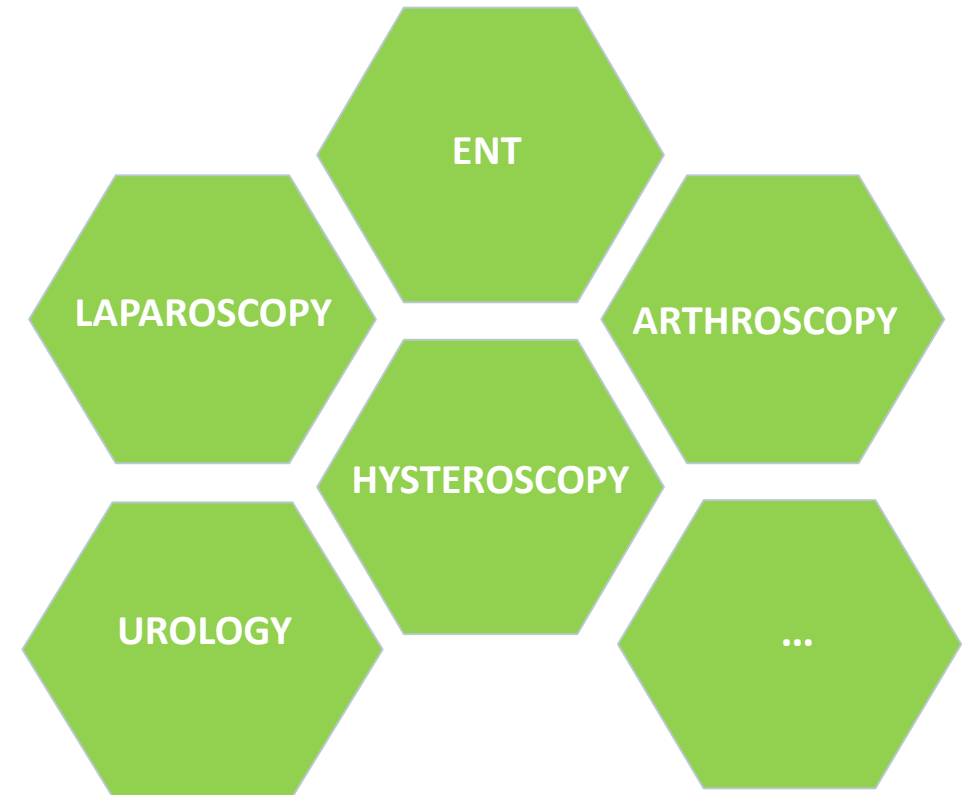

2. IMAGE FORMATION WORKFLOW

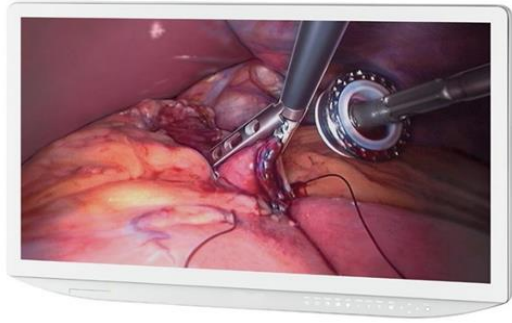

MEDICAL MONITOR



CAMERA CONTROL
UNIT (CCU)



CAMERA HEAD UNIT
(CHU)



LIGHT SOURCE



ENDOSCOPIC
TELESCOPE



TYPES OF CHIP TECHNOLOGY USED TO CAPTURE IMAGES DIGITALLY

CCD

Charge Coupled Device

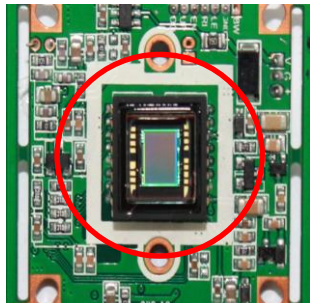

CMOS

Complementary Metal Oxide Semiconductor

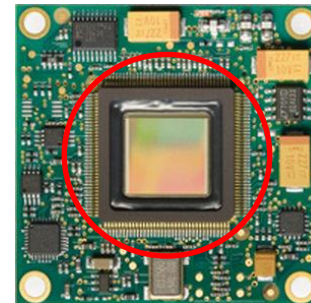

- **CCD** “charge coupled device” is an integrated circuit imprinted onto a silicon surface forming light sensitive elements called pixels.
- An electronic chip that converts photons to electrons for digital processing.
- Photons incident on this surface generate charge that can be read by electronics and turned into a digital copy of the light patterns falling on the device.



- **CMOS** “Complementary Metal Oxide Semiconductor” **sensor** is an electronic chip that converts photons to electrons for digital processing.
- Depend on the photoelectric effect to create electrical signal from light.
- Each pixel comes with its own charge-to-voltage conversion.
- The charge from the photosensitive pixel is converted to a voltage at the pixel site.



CCD

Charge transported across the chip and read at on corner of the array

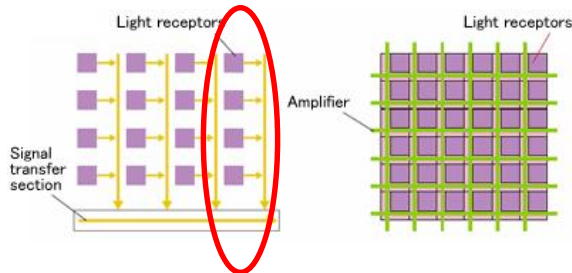
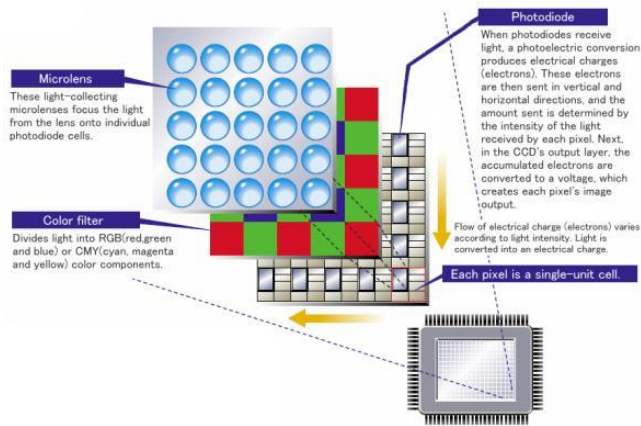

CMOS

Charge transported across every single transistor on each pixel

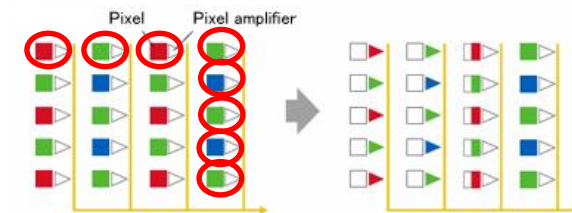
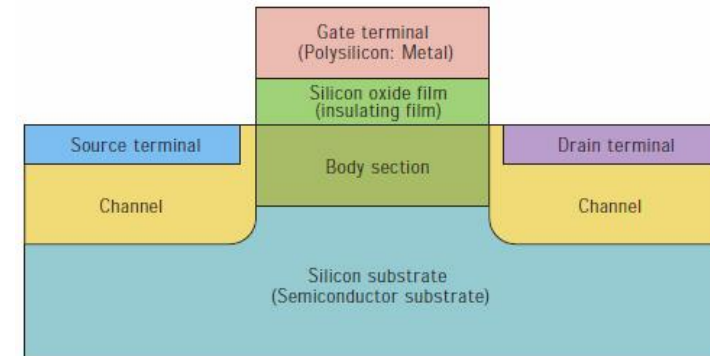

- **CCD** uses what's called a "Global Shutter" .
- **CMOS sensors** use a "Rolling Shutter ".
- Global Shutter means that the entire frame is captured at the exact same time.
- A Rolling Shutter captures light by capturing each pixel one-by-one.

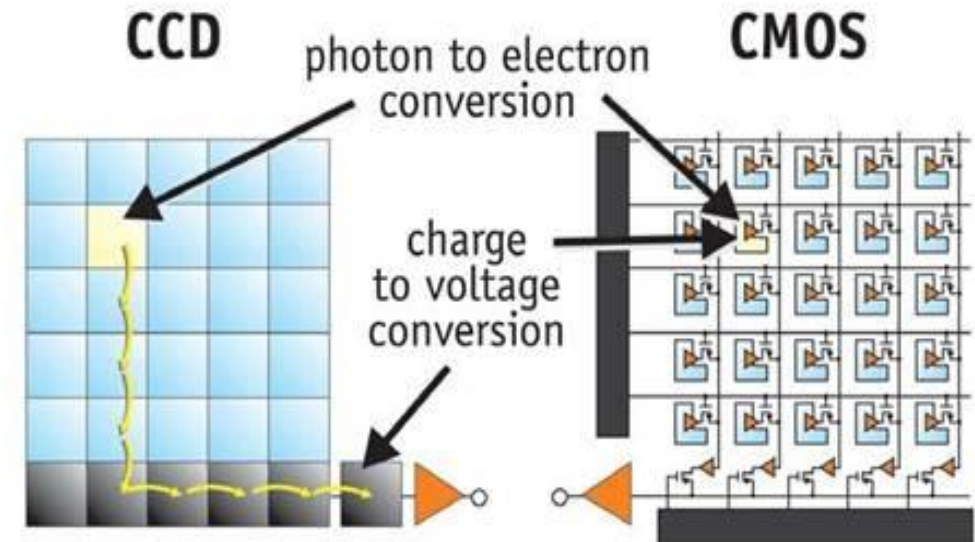

CCD:

- Old technology
- High cost

CMOS :

- New technology
- Low power
- Low cost

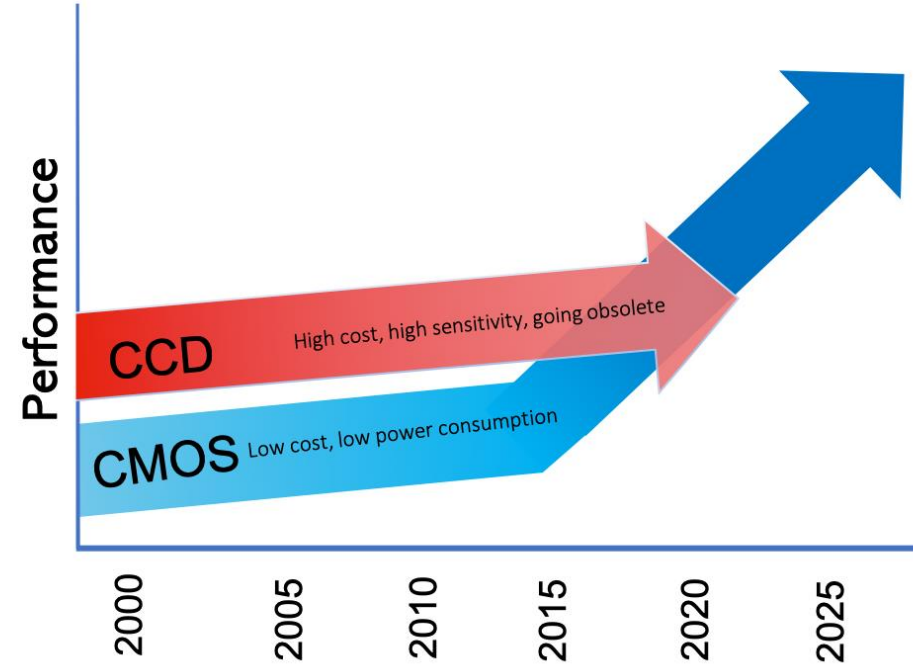

- Resolution refers to the number of pixels in an image.
- Image resolution is typically described in PPI, which refers to how many pixels are displayed per inch of an image.
- Higher resolutions mean that there more pixels per inch (PPI), resulting in more pixel information and creating a high-quality, crisp image.

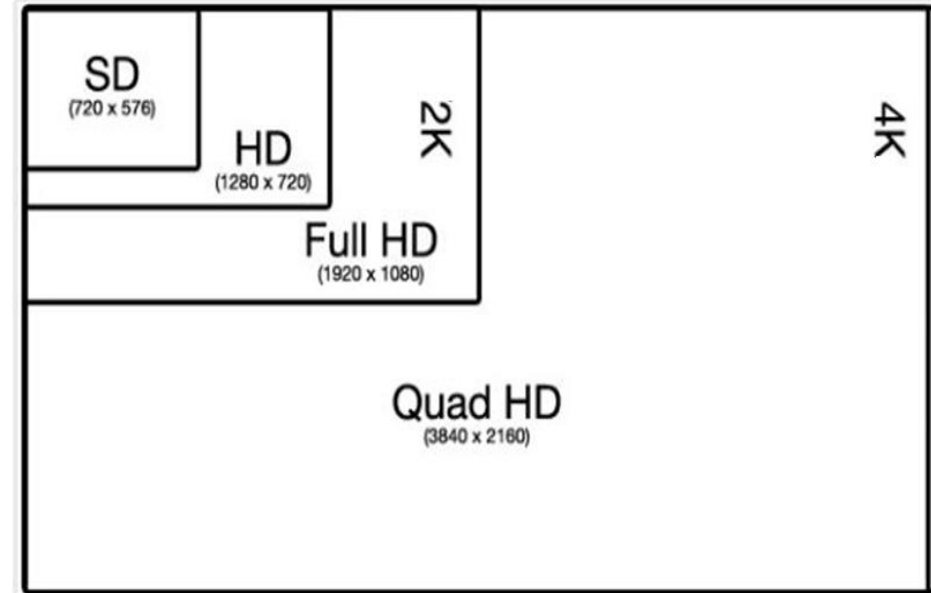

Four resolutions compared: standard definition, full high definition, Quad HD and 4K/2K.

- HD, FHD, 4K – more pixels, sounds reasonable but how do we feel the difference?

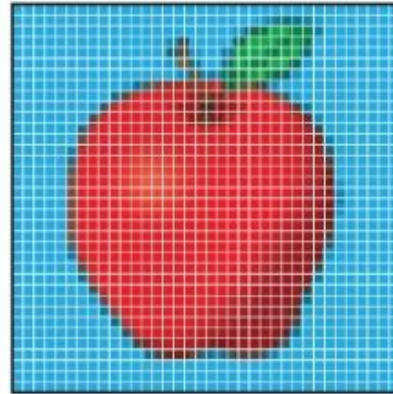
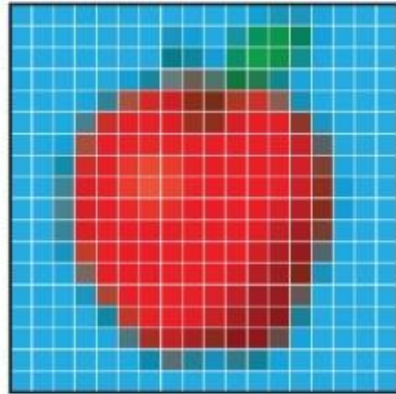
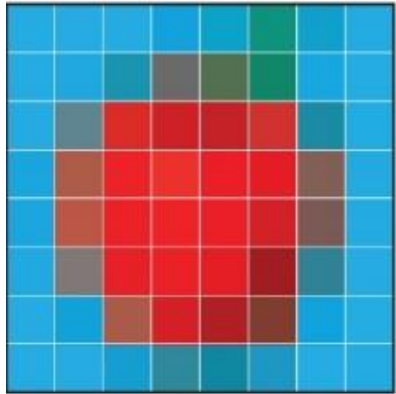

So it means if we have a sensor with bigger resolution, we can catch more details of the whole picture.

we can get similar image impression on a bigger screen.

WE CAN SEE MUCH MORE

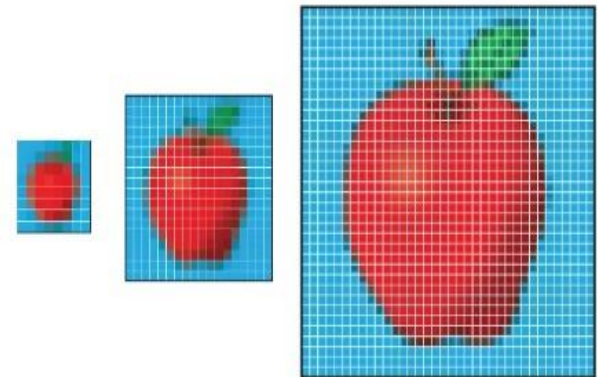

- With 4K camera sensor contains more pixel
- Ability to collect more information
- Capturing more details in the image

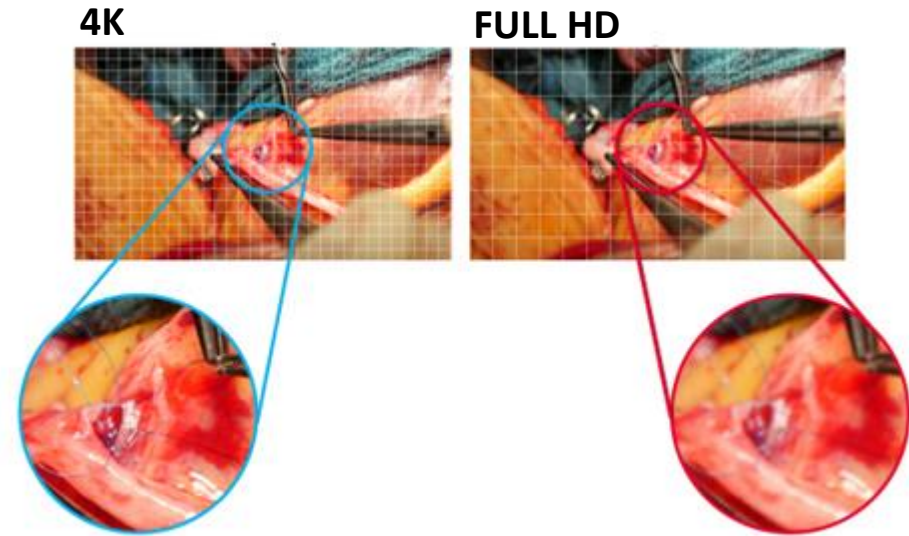

1. Contrast
2. Brightness
3. Frame rate
4. Field of view
5. Shutter speed
6. White Balance

- **Contrast means** difference, contrast is defined as the separation between the darkest and brightest areas of the image.
- In photography, the most common differences are achieved by changes in the tones or colors that compose the image.
- It is the degree of difference between the elements that form an image.



Low Contrast Image



High Contrast Image

- Refers to the overall lightness or darkness of the **image**.
- The quality or state of giving out or reflecting light.
- Brightness is the perception elicited by the luminance of a visual target. It is not necessarily proportional to luminance.

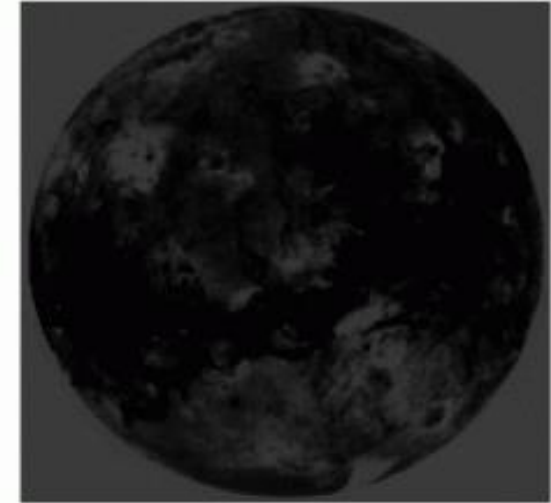

low Brightness

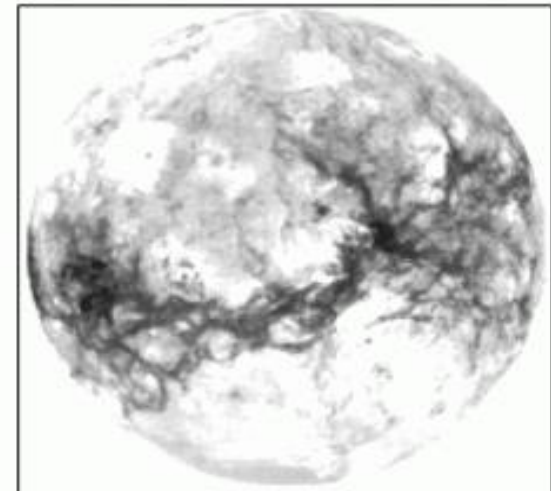

High Brightness

- Frame rate refers to the number of individual frames that contain each second of video you record, also known as FPS (frames per second.)
- The most common frame rates in video are 24, 25 and **30 frames per second.**
- 30 fps means the camera captured 30 frames in a single second of video.
- Higher frames, then smoother video.

- Lower **frame rates** can result in broken movement, ideal for locations without fast moving objects.
- Frame rate also has an impact on the **size of your video files**. A higher frame rate results in more frames, so the video file will be larger.
- If you are recording something fast like traffic, however, 30 fps would be necessary to smoothly record movement.

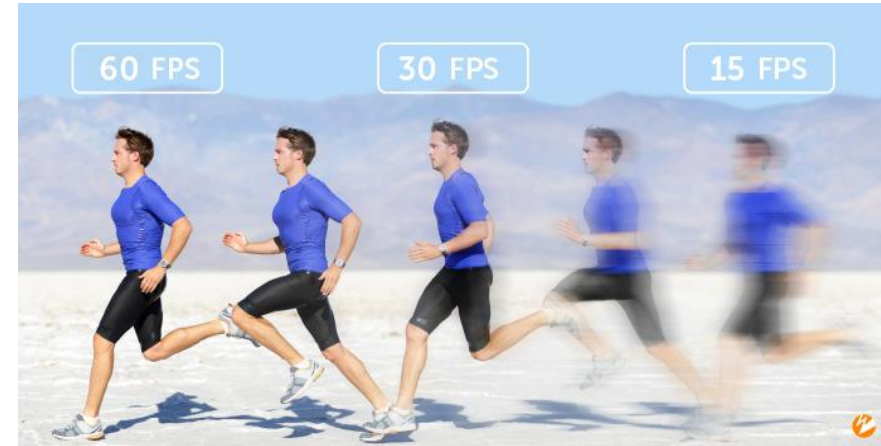

- Refers to the length that the **lens** will cover at a certain distance
- Depends on two factors: focal length of the lens and the sensor size.
- The focal length of the lens describes the distance between the lens and the focused image on the sensor.
- Sensor size is determined by both the size of the pixels and number of pixels on the sensor. Larger sensors optimal for sensitivity applications, and smaller sensors optimal for resolution applications.
- The field of view is defined as is the maximum area of a sample that a **camera** can **image**.

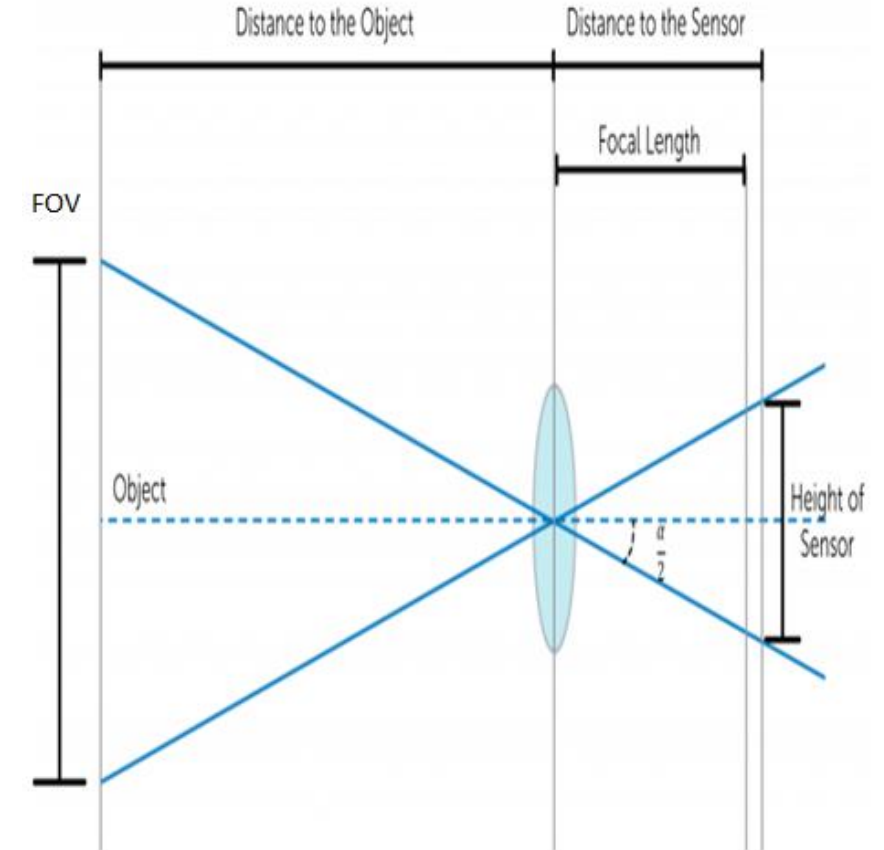

- Shutter speed is the *length of time* the camera shutter is open, exposing light onto the camera sensor.
- Shutter speeds are typically measured in fractions of a second for example, 1/4 means a quarter of a second.
- Shutter speed exists because of the camera shutter which is a curtain in front of the camera sensor that stays closed until the camera fires.
- When the camera fires, the shutter opens and fully exposes the camera sensor to the light that has passed through your lens.

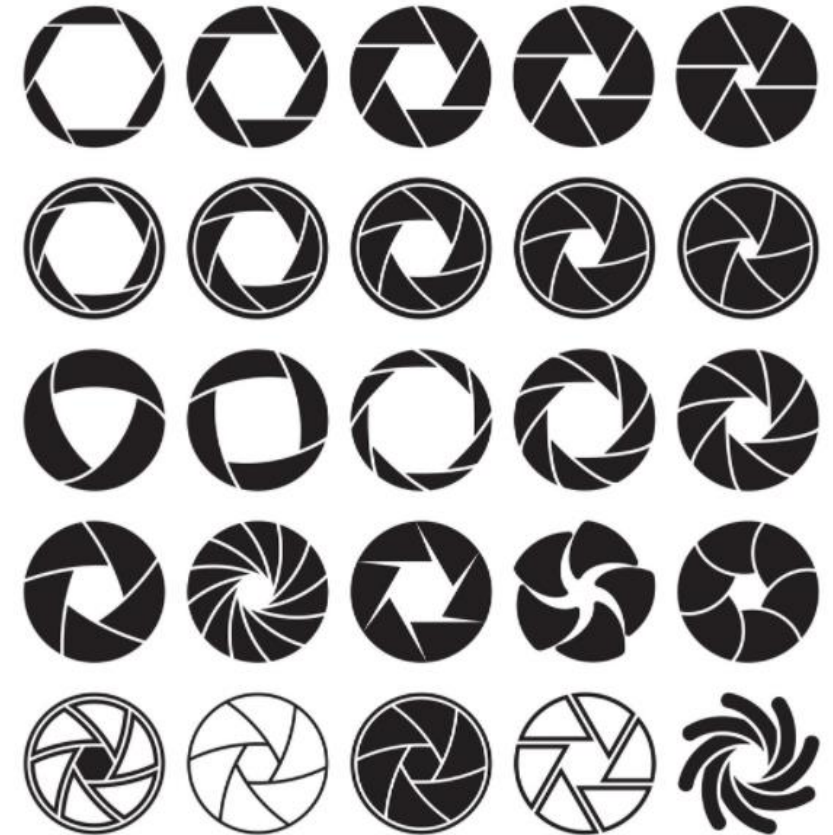

- The faster the **shutter speed** the easier it is to photograph the subject without **blur** and “**freeze**” motion and the smaller the effects of camera shake.
- When you use a long shutter speed (also known as a “slow” shutter speed), the first big effect of it is **motion blur**. If your shutter speed is long, moving subjects in your photo will appear blurred along the direction of motion.

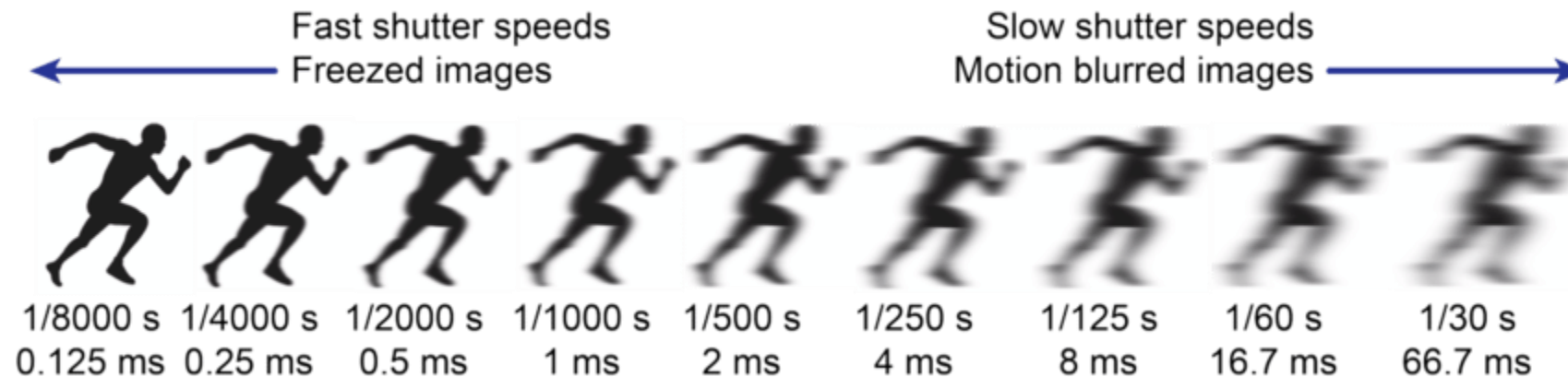

- **White balance** is the process of removing unrealistic color casts, so that tissue that appears **white** in real **are** rendered **white**.
- White balance is how the camera compensates for different light sources so the colors in the image look realistic in the video.



WITHOUT WHITE BALANCE



WITH WHITE BALANCE

The camera control unit is connected to the medical monitor via:

1. VGA
2. DVI
3. HDMI
4. SDI

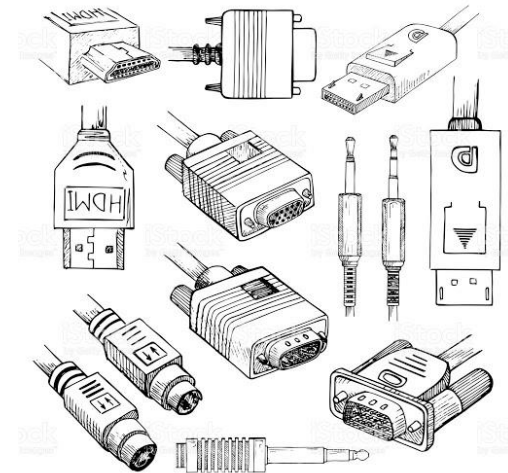

- **VGA** stands for VIDEO GRAPHICS ARRAY
- Transfers video signal only.
- **VGA** provides a maximum **resolution** of 640 x 480 at 60 Hz
- 0 - 5 meters transmission range
- Lock connector

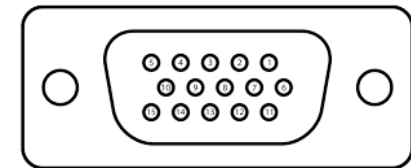

- DVI stand for Digital Visual Interface.
- Transfers video signal only.
- DVI support up to only 1920×1200 resolution at 144HZ.
- 0 -8 meters transmission range
- Lock connector



DVI-I (Dual Link)

- HDMI stand for High Definition Multimedia Interface.
- Transfer both high definition **audio and video** over a single cable.
- HDMI support up to 4K at 60 Hz.
- 0 - 40 meters transmission range

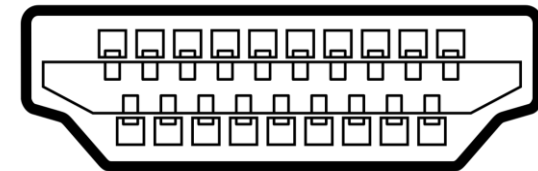

- Stands for Serial Digital Interface
- Transfer both audio and video over a single cable.
- HDMI support up to 4K at 60 Hz.
- 0 - 400 meters transmission range
- Lock connector

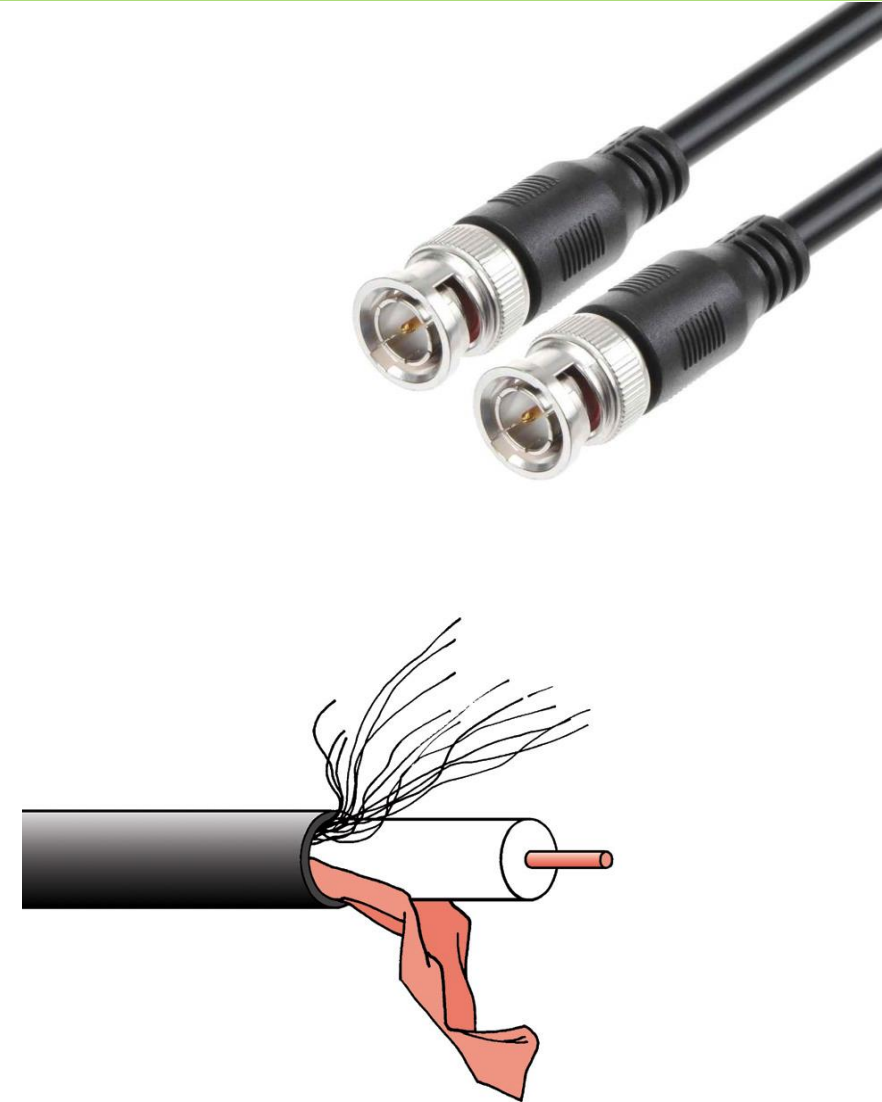

Connection	Transfer Audio	Transmission Range	Lock Connector
DVI	No	8 meters	Yes
HDMI	Yes	40 meters	No
SDI	Yes	120-400 meters	Yes

- In order to stream 4k video you only have three options :
- 6G-SDI
- 12G-SDI
- Quad Link SDI (take four 3G SDI signals and bond them together)

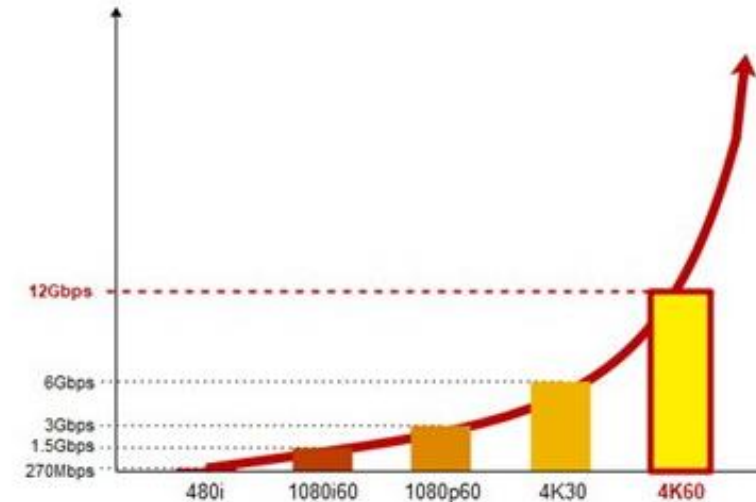

- SPECTRA 4K VISION ®
- SPECTRA VISION III ®
- EPSILON VISION I ®
- URSAE VISION ®

The new INGENIOUS camera platform **SPECTRA 4K VISION** offers you the flexibility you need to succeed in your market: Today, Tomorrow and in the Future.

- High-end 4K UHD and Full HD outputs for maximum flexibility.
- Optimized settings for different interventions such as laparoscopy, arthroscopy, gynecology, urology, ENT, etc...

SPECTRA 4K VISION camera offers:

1. Outstanding performance
2. Image / video capturing via USB
3. Video algorithms
4. Multi-connectivity
5. Automatic Light Control



OUTSTANDING PERFORMANCE

- 4K UHD imaging (3840 x 2160, 50 / 60p)
- BT2020, large UHD color space enabling the display of highly saturated colors
- 3 CMOS Sensor
- 2 x optical zoom (plus 3 x digital zoom)
- Unique lockable endoscope connection
- STERRAD / Plasma - compatible



- A CMOS camera uses a single-chip, where 50% of the pixels are dedicated to Green and 25% each for Red and Blue.
- In the 3-CMOS camera, three sensors are used and each sensor is dedicated to one channel so there are more pixels per channel by a factor of 2X for green and 4X for red and blue.
- The combination of three-chip and pixel offset provides a significant increase in data and resolution.

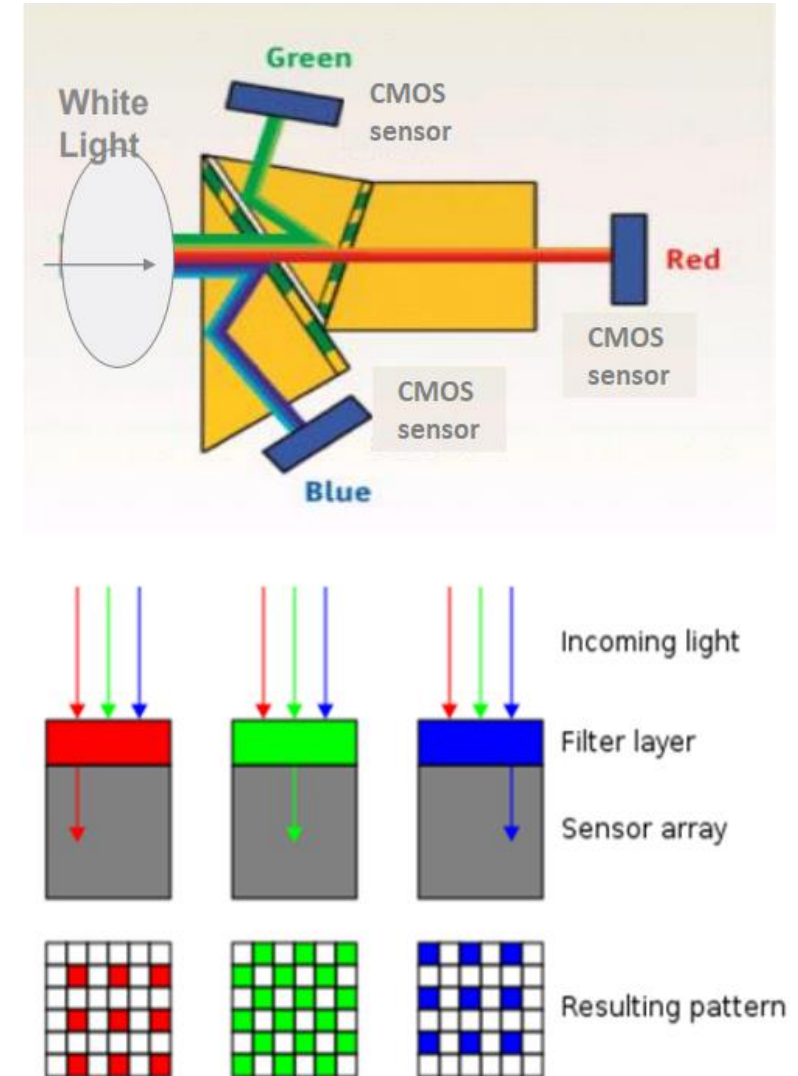
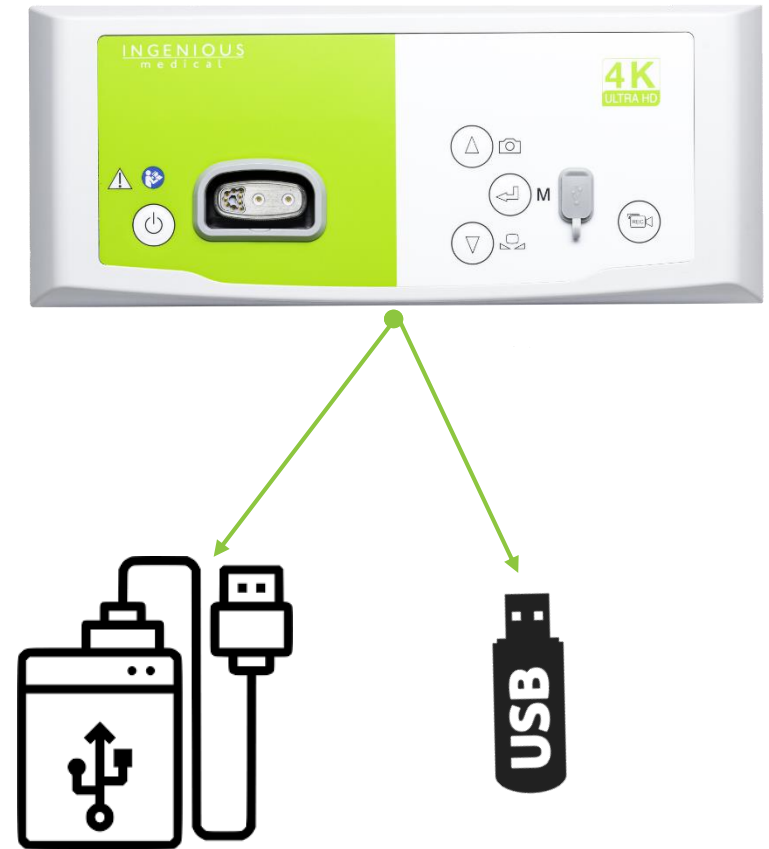

IMAGE / VIDEO CAPTURING VIA USB

- Build-in recorder
- Image and video capturing
- FULL HD recording resolution
- Compatible with FT 32 USB format (Available in all markets)
- Compatible with any External hard disk



FEATURES ENHANCEMENT

- Refers to SCE “Selective Color Enhancement”
- Intensify the predominant color in the image
- Used to better differentiate structures from one another in an environment with little difference in color
- Mainly helpful to accentuate the colors of vessels for tissue biopsy
- NOTE: SCE changes the natural color representation >> “ATTENTIONS: false color rendering” is displayed on the screen as long as this setting is activated



COLOR ENHANCEMENT

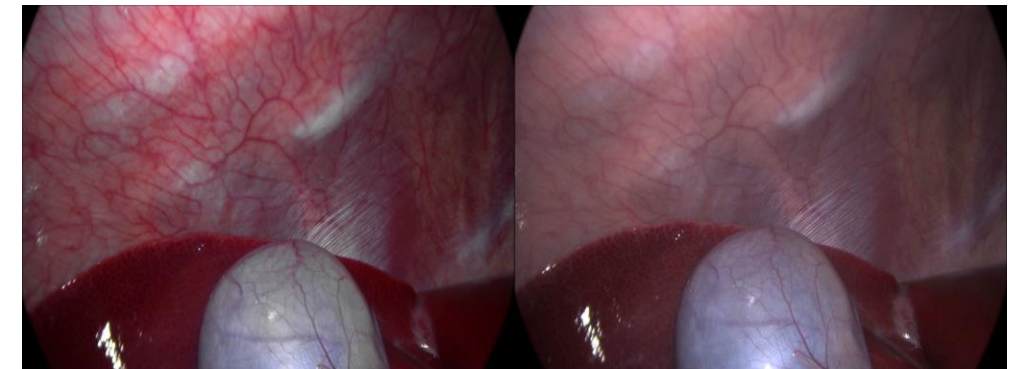

SMOKE REDUCTION

- Allows a clearer image in a smoke-filled environment
- Mainly helps when there is coagulation with electrosurgical units
- Used to compensate for a poor view due to smoke formation
- NOTE: smoke reduction create a very contrast –rich image and can promote blooming

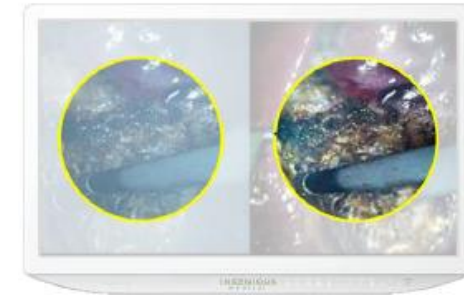

SMOKE REDUCTION



COLOR SHIFT

- Changes the color of vessels and tissue structure
- Used for a better view of vessels and tissue structures
- NOTE: Color shift 1/2 alters the natural color representation >> the message “Color Shift 1 or Color Shift 2” is displayed on the screen as long as this setting is activated

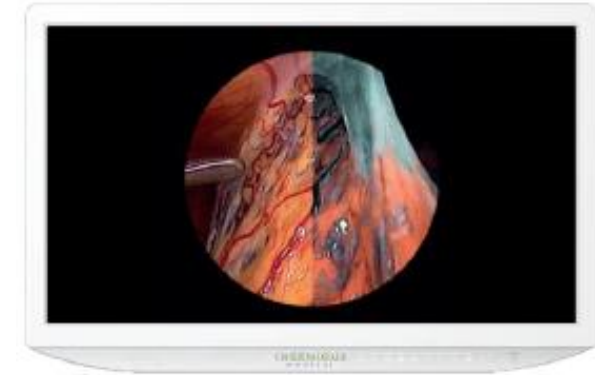

COLOR SHIFT 1/2

GRID REMOVAL

- Reduces or removes the grid that is caused by use of image bundle systems
- Used to suppress interfering grids
- NOTE: Grid removal causes a slight reduction in image sharpness



GRID REMOVAL

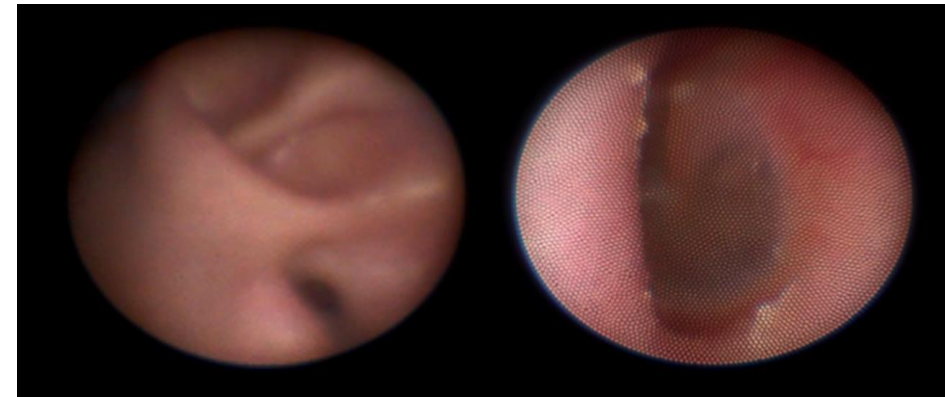

MULTI-CONNECTIVITY

1. Spectra 4K Vision could be connected to:
2. Full HD camera head
3. Angled Full HD camera head
4. 4K UHD camera head

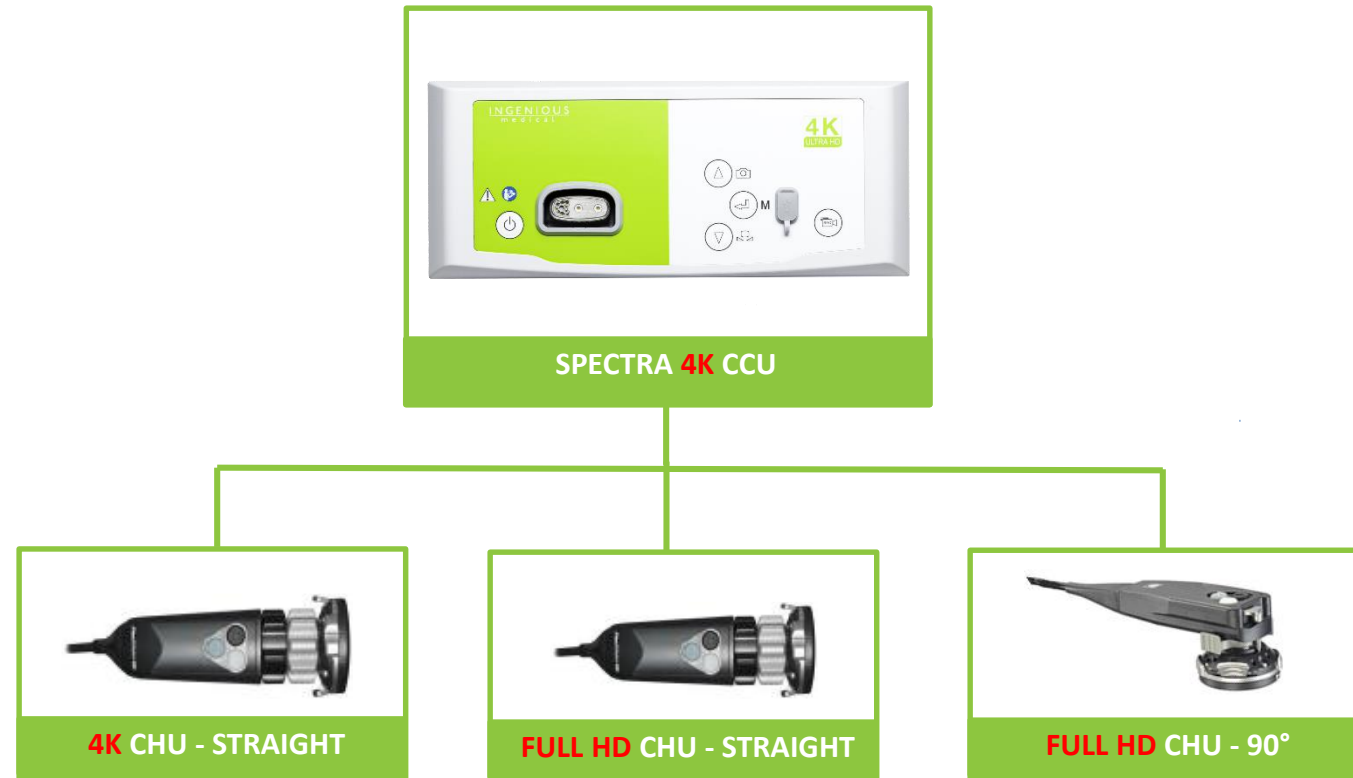

AUTOMATIC LIGHT CONTROL

- Large color gamut BT.2020
- Large UHD color space enables the display of highly saturated colors
- Connected to SPECTRA LED 300 which has a CRI Ra >90 together offer two essential features for outstanding color reproduction.
- The camera controls the required amount of light fully automatically

A perfect match for colors



MIS-BUS INTERFACE



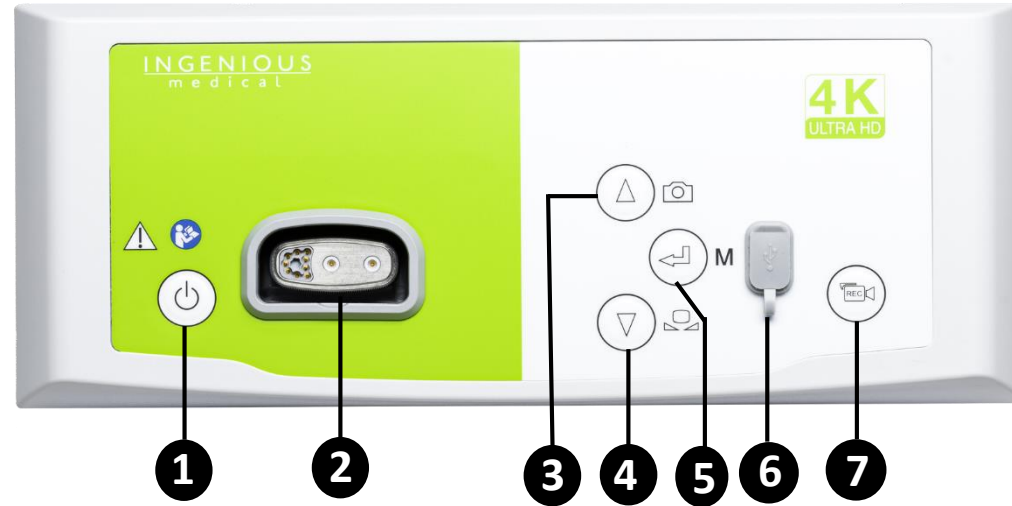

- 1** ON/standby button
- 2** Connection for camera head
- 3** Photo capture button/Upwards in menu

- 4** Balance button/Downwards on menu
- 5** Open Menu/Enter
- 6** USB storage device connection
- 7** Video capture start/Stop button

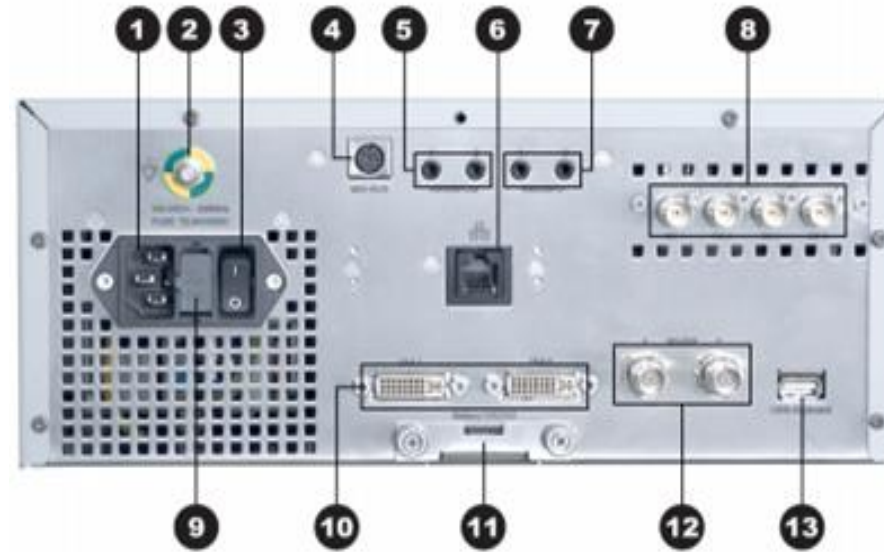

- | | |
|---|--|
| 1 Appliance coupler | 7 Foot switch connection (Remote in) |
| 2 Potential equalization terminal | 8 4*3G SDI output for 4K/UHD |
| 3 Main power witch | 9 Fuse Holder |
| 4 MIS-Bus | 10 2*DVI output |
| 5 Recording Device connection (Remote out) | 11 Battery compartment (VARTA CR2032) |
| 6 Port For service (covered) | 12 2*3G SDI output |
| | 13 USB Keyboard connection |

- SPECTRA 4K VISION could be connected:
- To a 4k/UHD medical monitor via 4x 3G-SDI
- To FHD medical monitor via DVI ports
- To foot switch via Remote-In 1 and Remote-In 2
- To keyboard via USB
- To recorder via 4x 3G-SDI connections, a DVI, or a 3GSDI connection





Patient ID

123456789

Name

Doe

First name

John

Date of birth

23.06.1982

Gender

Male

Application

Laparoscopy

Surgeon

Dr. Jane Doe

Date

24.10.2014

Laparoscopy	
Patient	
Patient ID	123456789
Name	Doe
First name	John
Date of birth	23.06.1982
Gender	Male
Application	Laparoscopy
Surgeon	Dr. Jane Doe
Date	24.10.2014

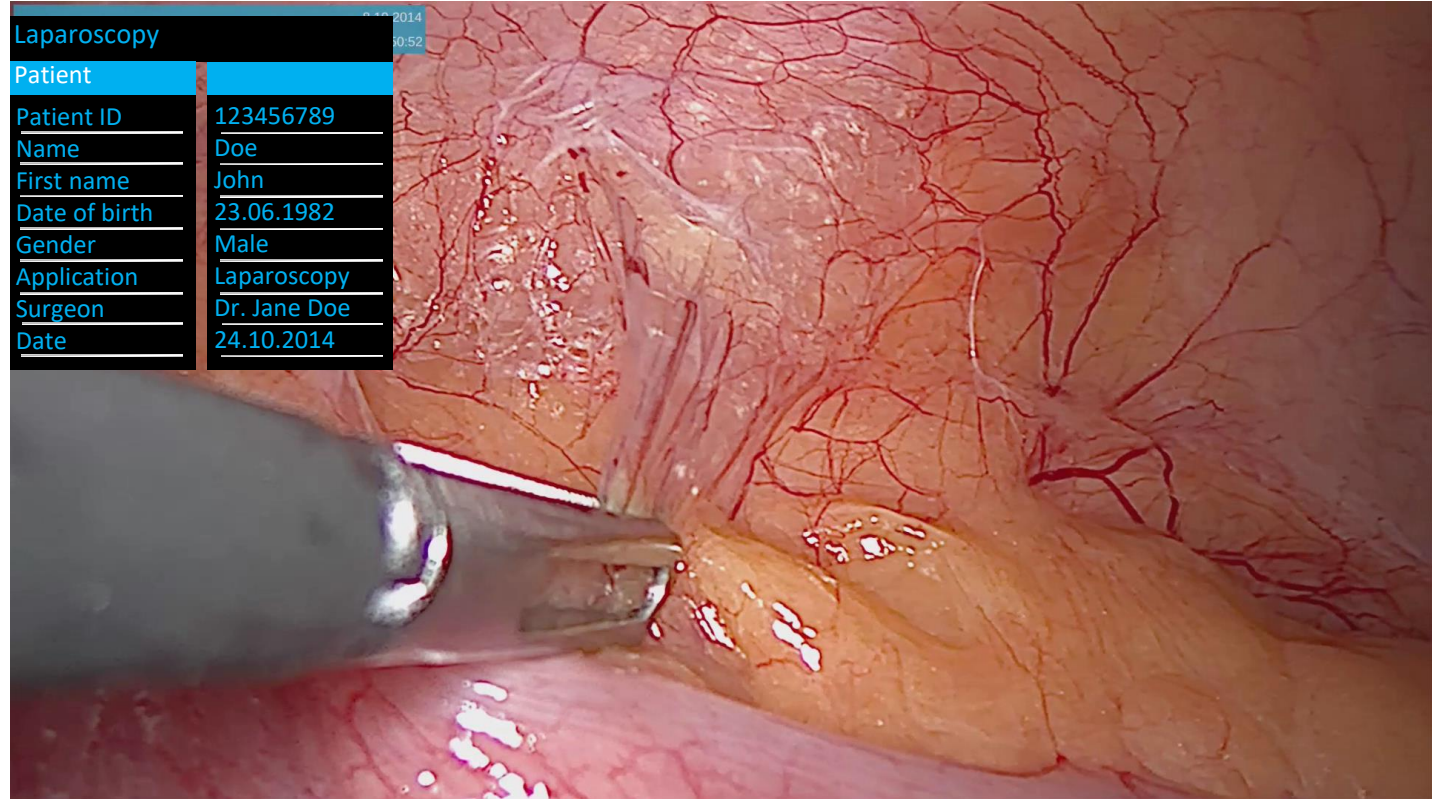



Selectable Button Function:

- Lightsource On/Off
- White Balance
- Image Snapshot
- Video Recording
- Contrast +/-
- Selective Color Enhancement,
- Smoke Reduction
- Remote
- Grid Removal
- Light +/-
- Brightness +/-
- Saturation +/-
- Zoom +/-
- Edge Enhancement +/-
- Color Shift 1/2

Standard Configuration

Long Press

- Menu Entry (not changeable)

Short Press

- Image Snapshot

Standard Configuration

Long Press

- Remote

Short Press

- Light -

Standard Configuration

Long Press

- White Balance

Short Press

- Light +

Every key can be programmed with each function either on **SHORT PRESS** or **LONG PRESS**.

Resolution	3840 x 2160 pixels
Image Sensor	3 x 1/3 CMOS
Scanning	Progressive scanning
Parafocal zoom	F = 14.25 - 28 mm
Length camera cable	3.5 m
Weight camera head	330 g
Sterilization	Sterrad - compatible

The new INGENIOUS camera platform **SPECTRA VISION III** offers you the flexibility you need to succeed in your market.

- Native **FULL HD** camera offers:
 1. Outstanding performance
 2. Image / video capturing via USB
 3. Video algorithms
 4. Multi-connectivity
 5. Light Intensity control
 6. UPSCALING CAPABILITY TO 4K RESOLUTION



OUTSTANDING PERFORMANCE

- FULL HD imaging (1920 x 1080, 50 / 60p)
- CMOS Sensor
- 2 x optical zoom (plus 3 x digital zoom)
- Unique lockable endoscope connection



IMAGE CAPTURING VIA USB

- Build-in recorder
- Image capturing
- FULL HD resolution
- Compatible with any USB format
- Compatible with any External hard disk

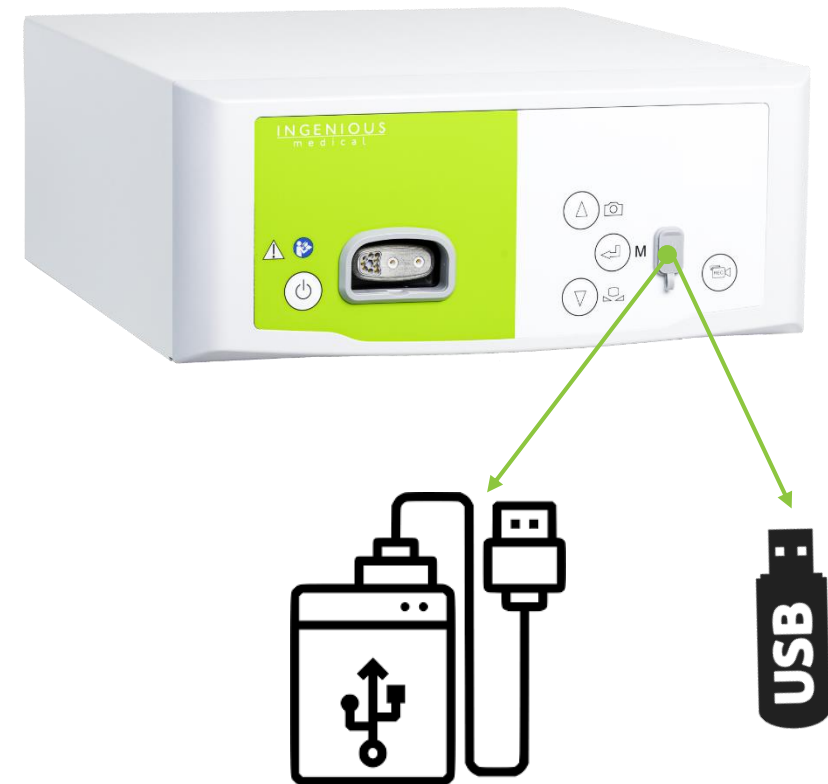

SELECTIVE COLOR ENHANCEMENT

- Refers to SCE “Selective Color Enhancement”
- Intensify the predominant color in the image
- Used to better differentiate structures from one another in an environment with little difference in color
- Mainly helpful to emphasize the colors of vessels
- NOTE: SCE changes the natural color representation >> “ATTENTIONS: false color rendering” is displayed on the screen as long as this setting is activated

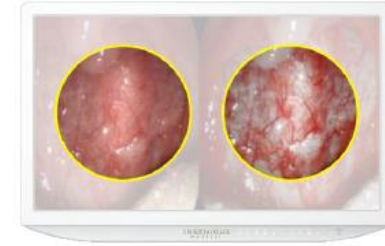

SELECTIVE COLOR ENHANCEMENT

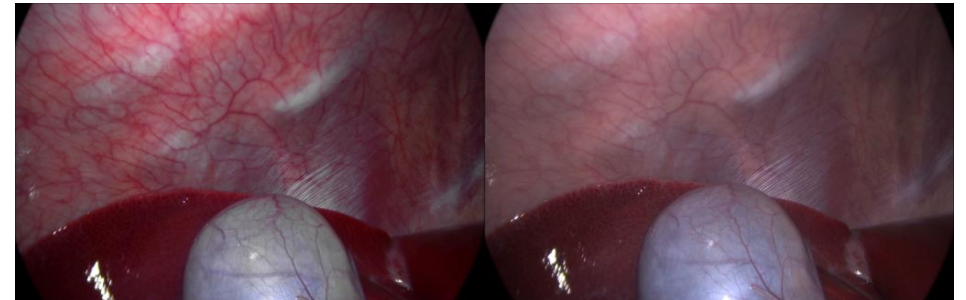

SMOKE REDUCTION

- Allows a clearer image in a smoke-filled environment
- Mainly helps when there is coagulation with electrosurgical units
- Used to compensate for a poor view due to smoke formation
- NOTE: smoke reduction create a very contrast –rich image and can promote blooming

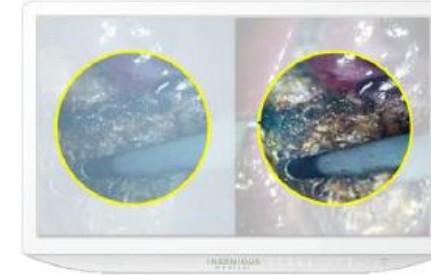

SMOKE REDUCTION

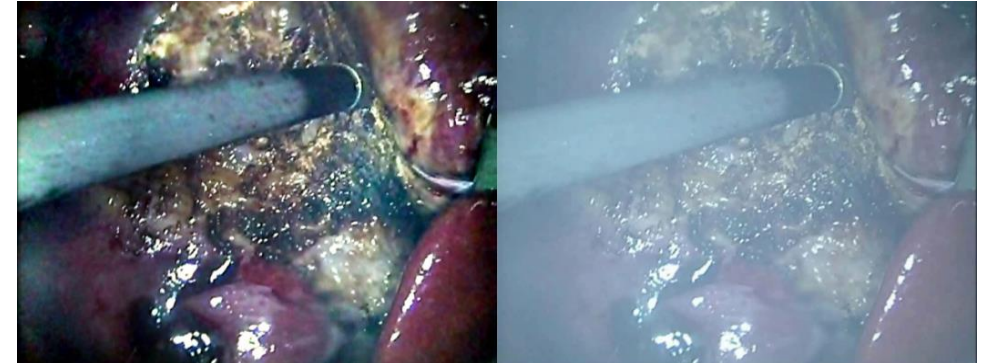

GRID REMOVAL

- Reduces or removes the grid that is caused by use of image bundle systems
- Used to suppress interfering grids
- NOTE: Grid removal causes a slight reduction in image sharpness



GRID REMOVAL

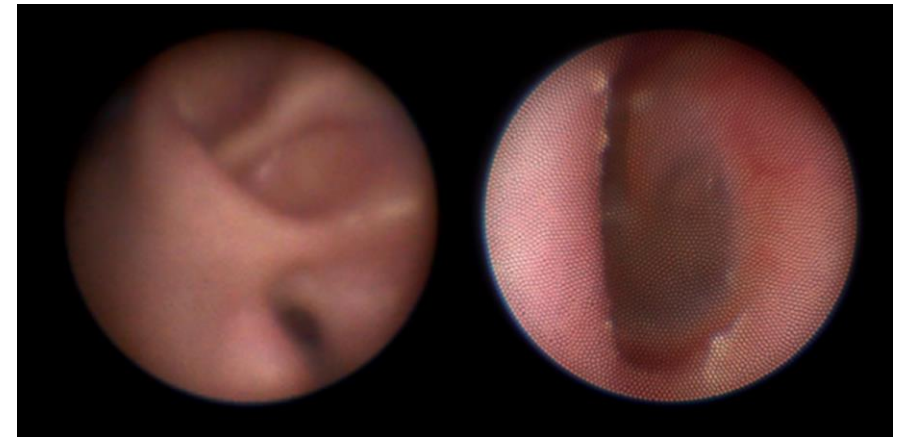

Spectra Vision III could be connected to:

1. Full HD camera head
2. Angled 90° Full HD camera head

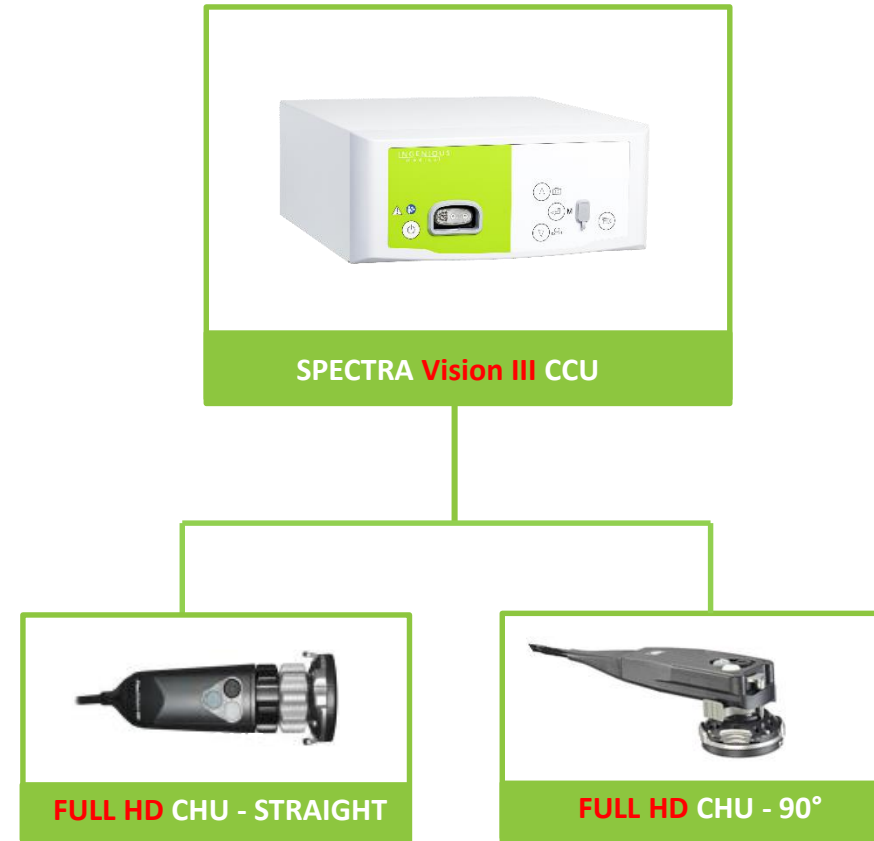

LIGHT INTENSITY CONTROL

- MIS-Bus System
- BUS connectivity to the INGENIOUS SPECTRA VISION Cameras
- Camera and LED can communicate with each other!
- The LED light source can be adjusted remotely by the user via the buttons on the camera head
- Intuitive control and use of the system



UPSCALING CAPABILITY TO 4K RESOLUTION

- Efficient while connecting CCU to SONY 4K monitors.
- Upscaling gives crisp, natural 4K view of lower resolution (without blurring or 'jaggies').





- 1** ON/standby button
- 2** Connection for camera head
- 3** Photo capture button/Upwards in menu
- 4** Balance button/Downwards on menu
- 5** Open Menu/Enter
- 6** USB storage device connection



- 1** Power cable socket
- 2** Fuse holder
- 3** Main power switch
- 4** MIS-Bus
- 5** Recording Device connection (Remote out)
- 6** Foot switch connection (Remote in)
- 7** Potential equalization connection
- 8** 2*DVI output
- 9** 2*HD-SDI output
- 10** Keyboard connection
- 11** Port for service

SPECTRA VISION III could be connected:

- To FHD medical monitor via 2x DVI port , 2x 3G-SDI
- To foot switch via Remote-In 1 and Remote-In 2
- To keyboard via USB
- To recorder via DVI, or an HD-SD
- To light source via MIS port

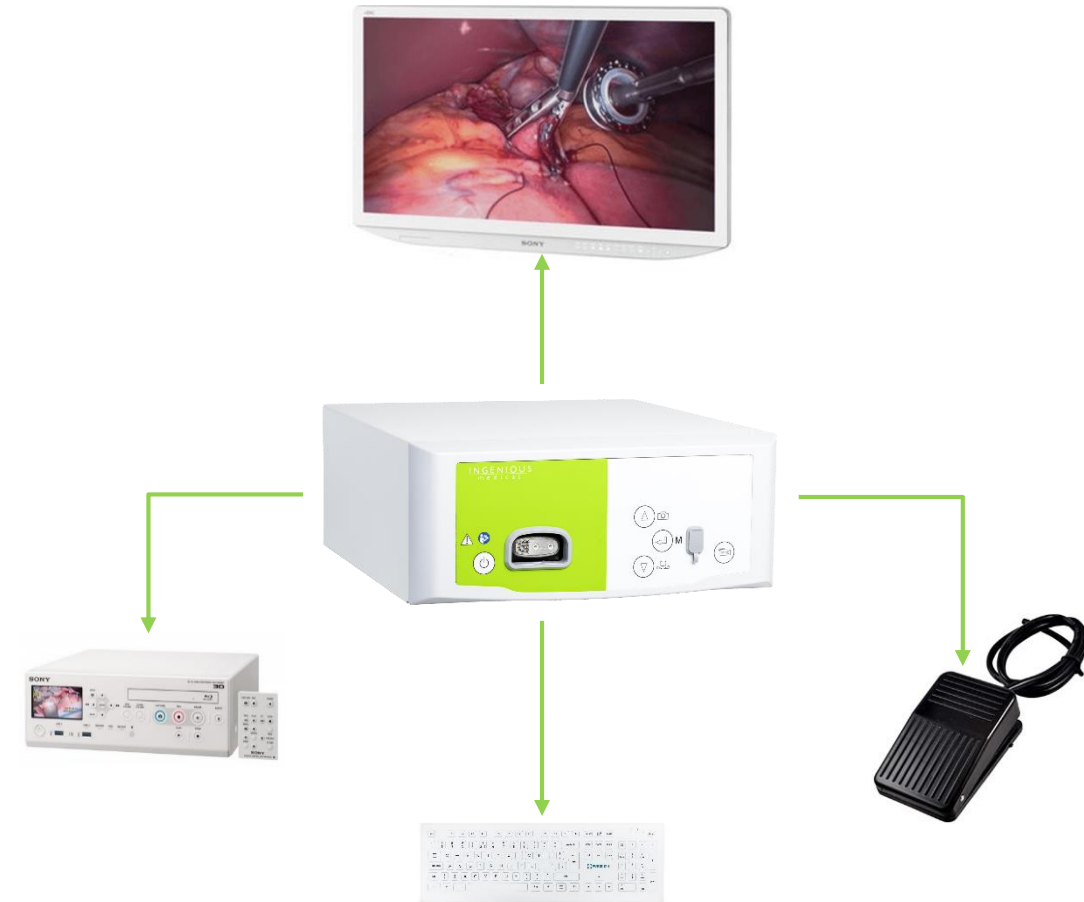

Selectable Button Function:

- Lightsource On/Off
- White Balance
- Image Snapshot
- Contrast +/-
- Selective Color Enhancement,
- Smoke Reduction
- Remote
- Grid Removal
- Light +/-
- Brightness +/-
- Saturation +/-
- Zoom +/-
- Edge Enhancement +/-



Standard Configuration

Long Press

- Menu Entry (not changeable)

Short Press

- Image Snapshot

Standard Configuration

Long Press

- Remote

Short Press

- Light -

Standard Configuration

Long Press

- White Balance

Short Press

- Light +

Every key can be programmed with each function either on **SHORT PRESS** or **LONG PRESS**.

Resolution	1920 x 1080 pixels
Image Sensor	1/3 CMOS
Scanning	Progressive scanning
Parafocal zoom	F = 14.25 - 28 mm
Length camera cable	3.5 m
Weight camera head	210 g
Sterilization	Soackable only

EPSILON VISION I delivers a clear and sharp picture with native progressive scan. Considered one of the best mid-range FULL HD camera available in the market providing the sharpest detail with incomparable natural color rendition at the highest spatial and temporal resolution.

EPSILON VISION I camera offers:

- 1. Basic Camera Controller**
- 2. FULL HD 1 Chip CMOS Camera System 1920 x 1080**
- 3. USB port for photo and video capturing**



PROGRAMMABLE CONTROL BUTTONS

3 Camera buttons Are available

DIGITAL ZOOM

Up to 2.5 x

FIVE ENDOSCOPE PRROFILES

for using different type of surgical
procedures

MULTI-FUNCTIONS

Mirror, freeze & rotation

DIGITAL EDGE ENHANCEMENT

Clarify edges during image display



PARAFOCAL ZOOM COUPLER

F = 13 -32 mm



ADVANCED COLOR ENHANCEMENT

Including clarify and color enhancement

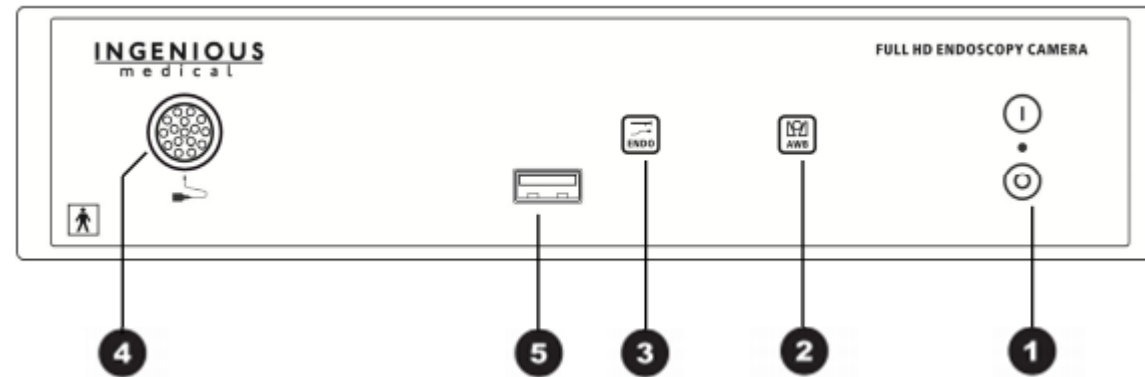

- 1** Power On/Off
- 2** White balance button/black balance function
- 3** Endoscope working mode button/Menu function
- 4** Camera head connection
- 5** USB Port for recording (optional)

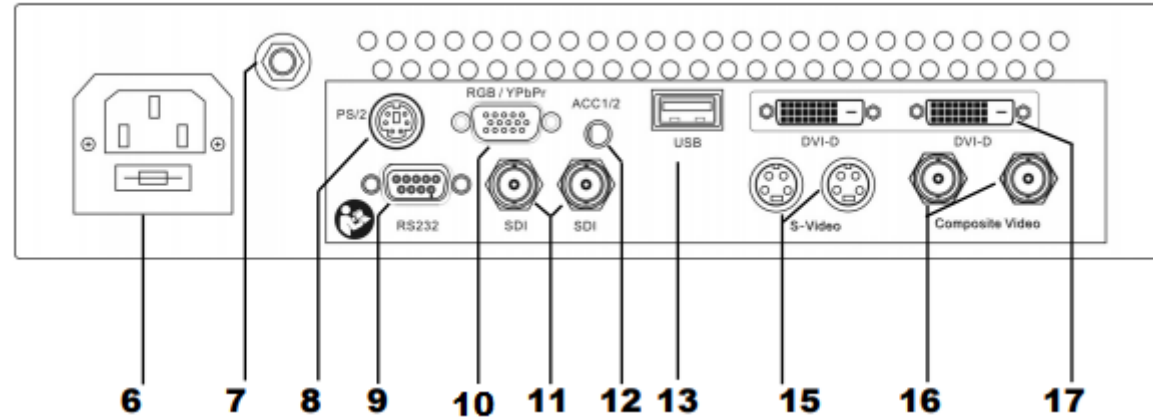

- 6 Power input connector
- 7 Socket for potential equalization
- 8 PS/2 Keyboard connector
- 9 RS-232 communication port
- 10 RGB/YPbPr, VGA analog output
- 11 3G-SDI/HD-SDI digital outputs
- 12 Acc.(Rec./PRT.) control output
- 13 USB port on back panel
- 15 S-Video outputs
- 16 Composite video outputs
- 17 DVI-D outputs

Resolution	1920 x 1080 pixels
Image Sensor	1 x 1/3 CMOS
Scanning	Progressive scanning
Parafocal zoom	F = 13 - 32 mm
Length camera cable	3 m
Weight camera head	90 g (without zoom coupler)
Sterilization	Soackable



EPSILON VISION I could be connected:

- To FHD medical monitor via 1x DVI port or HDMI ,2 x S-Video,2 x composite video
- To 2 controllable peripherals, via 2 x 3.5mm stereo Jack connector
- To keyboard via PS/2
- To recorder via DVI, or an HD-SD
- To PC via serial data interface.

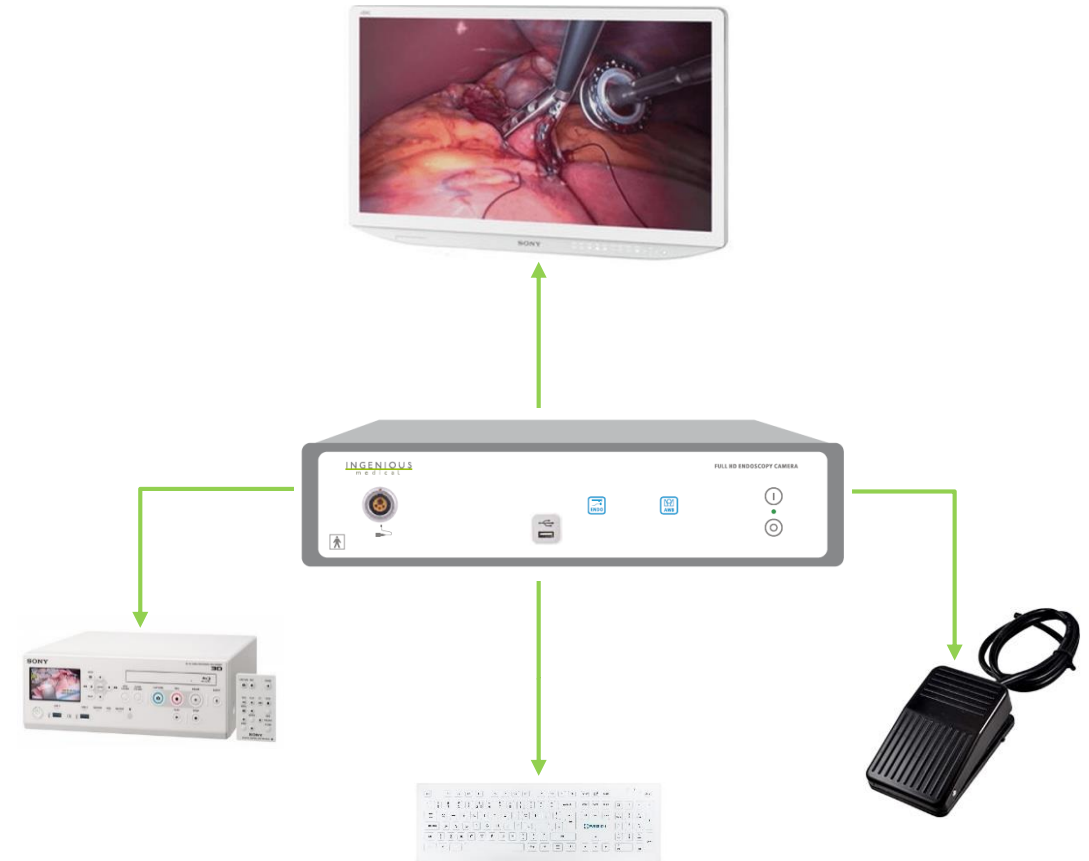

OUTSTANDING PERFORMANCE

- 4K UHD imaging (3840 x 2160, 50 / 60p)
- BT2020, large UHD color space enabling the display of highly saturated colors
- 3 CMOS Sensor
- 2 x optical zoom (plus 3 x digital zoom)
- Unique lockable endoscope connection
- STERRAD / Plasma - compatible



INGENUITY
FOR
HEALTH



INGENIOUS

m e d i c a l

■ INGENUITY
■ FOR
■ HEALTH

THANK YOU

INGENIOUS

m e d i c a l